

GrabTec

Backhoe Grapple

OWNER'S MANUAL

Includes all Installation Instructions

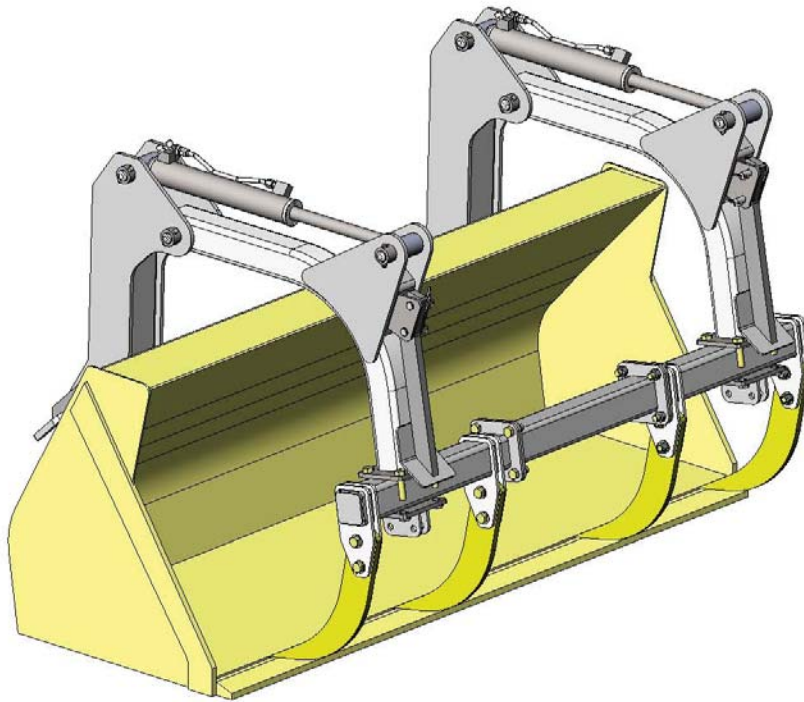

MODELS

GB77, GB83, GB89

© Grabtec
www.grabtec.com
email: sales@grabtec.com

Feb 2012

Install Center/Shipping/Receiving:
1242 Arizona Ave
Larchwood, IA 51241
(888) 857-8952
(712) 477-2675
FAX (712) 477-2500

PREFACE

This manual describes the installation, operation and maintenance of the Grabtec grapple. Please read and understand this manual in its entirety before performing installation, operation, or maintenance procedures to ensure the satisfactory performance and durability of the grapple. Read and follow all safety and precautionary notes included in this text. Any questions related to this product should be directed to Grabtec Customer Service at 1-888-857-8952 (712- 477-2675).

CONTENTS

Safety Statements	2
General Precautions	2
Installing Mount Kit onto the Bucket	3-7
Trimming "Universal" Mounts to Fit Bucket	8-9
Assembly of Grapple onto the Bucket	10-12
Quick-Disconnecting the Grapple from the Bucket	13-14
Quick-Connecting the Grapple to the Bucket	15-16
Adjustment of the Support Plates	17
Maintenance	18
Parts Listing (Index on page 19)	19-27
Identifying Grapple Model & Serial Number	28
Product Changes and Serial Break Info	28
Specifications	29
Warranty	30
Return Policy	31

SAFETY STATEMENTS



This statement is used where serious injury or death will result if the instructions are not followed properly.



This statement is used where serious injury or death could result if the instructions are not followed properly.



This statement is used where minor injury could result if the instructions are not followed properly.



This statement is used where equipment or property damage could result if the instructions are not followed properly.

GENERAL PRECAUTIONS

◇ **READ MANUAL PRIOR TO INSTALL or OPERATION**

Improper installation, operation, or maintenance of this equipment could result in serious injury or death. Operators and maintenance personnel should read all manuals related to this equipment thoroughly before beginning installation, operation, or maintenance.

◇ **AVOID ESCAPING FLUID that is under PRESSURE**

Escaping fluid under pressure can penetrate the skin causing serious injury. Relieve pressure before disconnecting hydraulic or other lines. Tighten all connections before applying pressure. Keep hands and body away from pinholes and nozzles which eject fluids under high pressure.

◇ **PROTECT AGAINST FLYING DEBRIS**

When driving connection pins, always guard against injury from flying pieces of metal or debris. WEAR GOGGLES OR SAFETY GLASSES.

◇ **SUPPORT RAISED EQUIPMENT**

Do not work under raised loader booms, buckets or grapples without supporting them. Lower booms, buckets and grapples onto blocks.

◇ **DO NOT MODIFY GRAPPLE**

Do not modify the grapple in any way without written authorization and instructions from Grabtec Customer Service at 1-888-857-8952 (712-477-2675). Modifications may weaken the integrity of the grapple and may impair the function, safety, usable life, and performance of the grapple.

◇ **DO NOT IMPROPERLY USE GRAPPLE**

Grapples are designed to be used as material handling tools for loading or transporting material that can be safely contained in the bucket the grapple is mounted on. Uses outside this method of material handling must be approved by Grabtec.

**INSTALLING MOUNT KIT
ONTO THE BUCKET**

NOTE

A mounting kit includes parts for each the left and right side of the bucket. Each side is usually identical to the other. The purpose of the diagram is to identify various parts of the kit. The spacers, alignment pins, and positioning template are used only during installation of the kit. They are purchased separately from the mounting kit. Your mount kit either included hook plates that are shaped to fit your bucket (like the ones shown on this page) or the hook plates are universal and need to be trimmed to fit (see pages 8-9 in this manual.)

MOUNT KIT (with Optional Assembly Kit items shown)

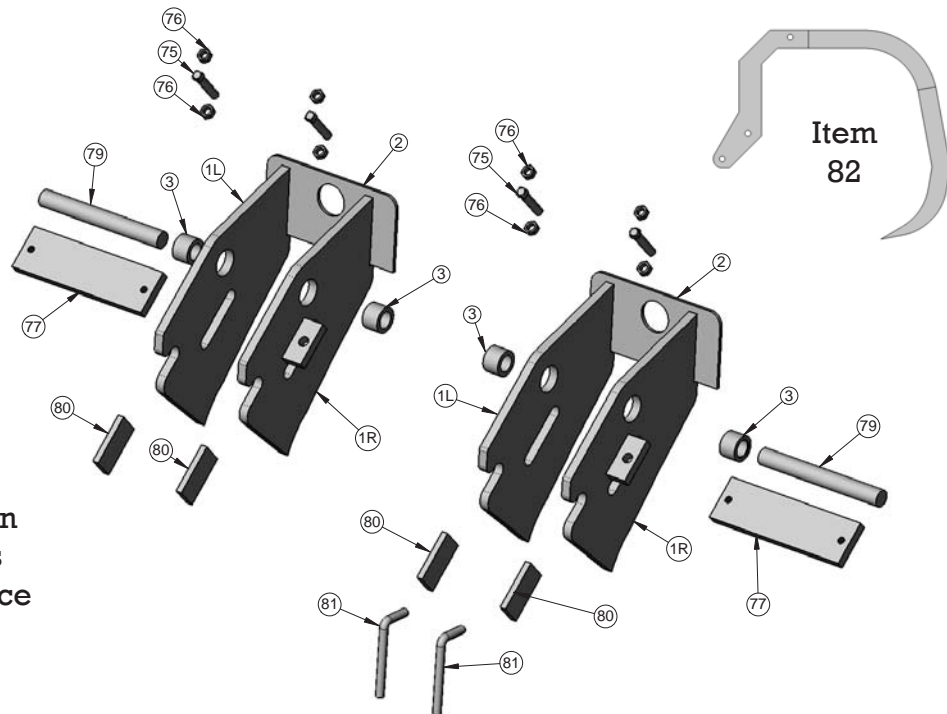

NOTE:
Shape and appearance of items 1L, 1R and 2 will depend on the application. This image is for reference only.

Mount Kit

ITEM	DESCRIPTION	QTY / KIT
1L	HOOK PLATE, LEFT	2
1R	HOOK PLATE, RIGHT	2
2	DOUBLER PLATE (NOT REQ'D FOR ALL KITS)	2
3	COLLAR (1.28" ID)	4
77	SUPPORT PLATE	2
75	SET SCREW, 3/4 X 4	4
76	JAM NUT, 3/4	8
81	J-HOOK	2

**Assembly Kit
(Optional)**

ITEM	DESCRIPTION	QTY / KIT
80	SPACER, 1/2" THICK, 2 X 4	4
79	ALIGNMENT PIN (1.27" DIA. x 11 LONG)	2
82	POSITIONING TEMPLATE (3 PIECES)	1

INSTALLING MOUNT KIT ONTO THE BUCKET

STEP 1 (See Figure 1)

This step is best done on a large bench. Slide the hook pin of the torque tube assembly into each "hook" of the hook plates. Slide the alignment pin through the long tapered sleeve of the torque tube and align it with the two 2" diameter holes of the hook plates. Slide a collar onto each end of the alignment pin and into the large holes of the hook plates so that the collars are flush with the inside of the hook plates. Insert one 1/2" thick spacer on each side of the torque tube and clamp the hook plates to the torque tube so that the space between the hook plates is 7".

STEP 2 (See Figure 2)

It is easier to work on the bucket when it has been removed from the loader. Put the bucket in the position shown and support it.

STEP 3 (See Figure 3)

Position the mount assembly made in Step on the back of the bucket and support it. The exact position will be determined in the next Step.

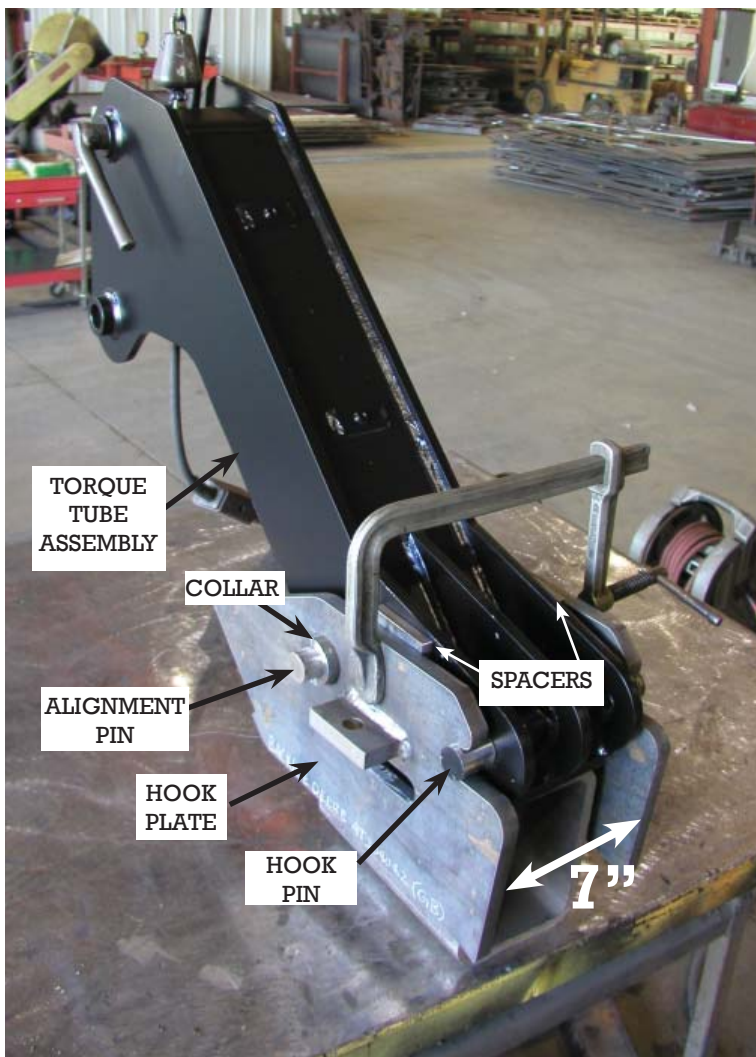

Fig. 1



Fig. 2



Fig. 3

INSTALLING MOUNT KIT ONTO THE BUCKET

STEP 4 (See Figure 4)

Place and support both mounts onto the back of the bucket. Each mount must be square with the other and square to the bucket so that the grapple does not bind as it rotates. The best results can be achieved by running a long 1-1/4" shaft or pipe through the grapple pivot holes on the torque tubes. The best center-to-center distance to use depends on the width of the grapple and also the presence of any obstructions on the back of the bucket, such as gussets or splash guards. Use the following table to help determine what center-to-center position of the mounts would work best in your application. If you need help determining what Model you have, see page 28. Once the location is finalized, mark all surfaces of the bucket where they contact the mounts. Sandblast or wire brush the bucket paint away in these areas so that all welding will be done on bare metal.

MODEL	GRAPPLE OVERALL WIDTH	CENTER-TO-CENTER OF MOUNTS**
GB77	77"	54" +/- 6"
GB83	83"	60" +/- 6"
GB89	89"	66" +/- 6"

** The mounts can be installed with a center-to-center spacing up to 6" wider than the standard spacing that is listed. However, the hydraulic branch hoses that are included with your grapple (see Items 2 & 3 on page 26) are only long enough for the standard center-to-center spacing.

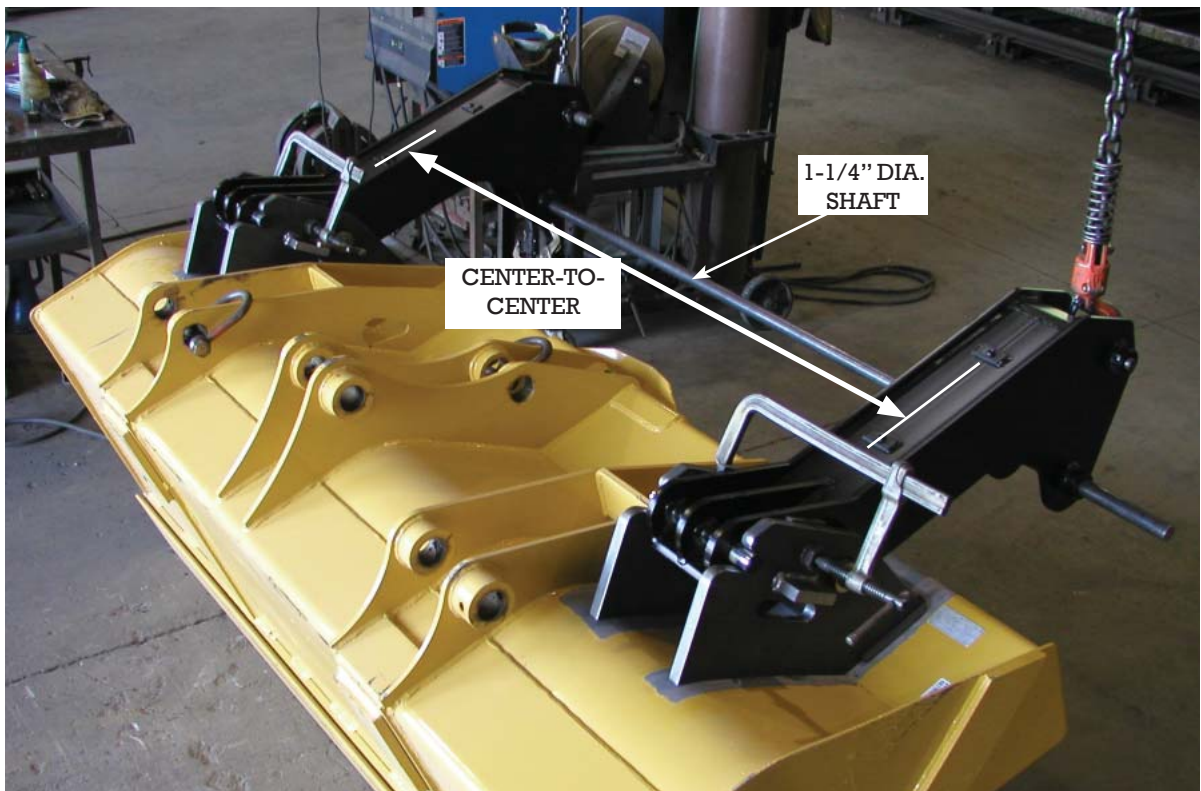

Fig. 4

INSTALLING MOUNT KIT ONTO THE BUCKET

STEP 5 (See Figure 5)

Once the mounts are square and properly spaced, tack the four hook plates to the bucket. **DO NOT TACK OR WELD THE COLLARS.**

STEP 6 (See Figure 6)

Remove clamps, spacers, collars, alignment pins and long alignment shaft from the mounts.

STEP 7 (See Figure 7)

Weld the hook plates (and doubler plate if applicable) to the bucket. A welder using 0.045 wire and capable of 250-300 amps works best. A 3/8" single-pass, continuous fillet weld is required for all parts that are being welded to the bucket.

Fig. 5

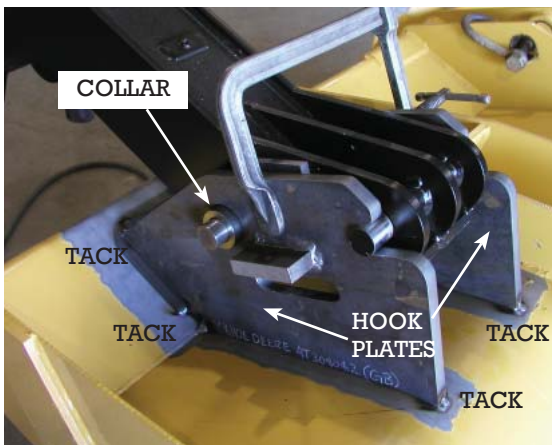

Fig. 6



Fig. 7

INSTALLING MOUNT KIT ONTO THE BUCKET

STEP 8 (See Figure 8)

With the bucket tilted forward, re-install the torque tube assemblies into the mounts. The downward tilt of the bucket will keep the weight of the torque tubes properly engaged in the hooks of the hook plates. Also install the collars into the hook tubes with the help of the alignment pin. The insides of the collars should be flush with the insides of the hook plates.

STEP 9 (See Figure 9)

Re-install the shaft that was used in Step 4 to square the torque tubes.

STEP 10 (See Figure 10)

Once you are comfortable with the position of the collars, tack the collars in their permanent position. If the tacks cause the collars to tighten up on the alignment pin(s), a few taps with a hammer on the collars should re-align them.

STEP 11 (See Figure 11)

Weld the collars in their permanent position. Note that there is welding on the outside of the hook plates only since the collars are flush with the insides of the hook plates.

STEP 12

Paint hook plates and all sand blasted areas.

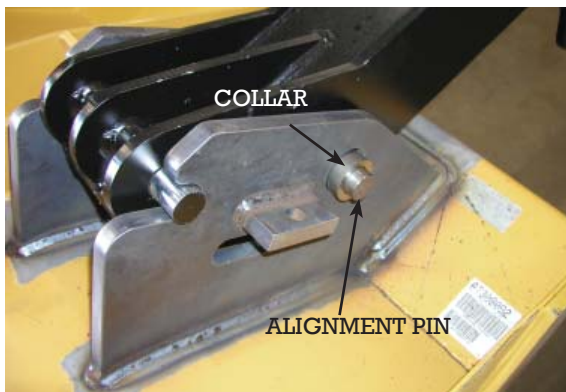

Fig. 8



Fig. 9

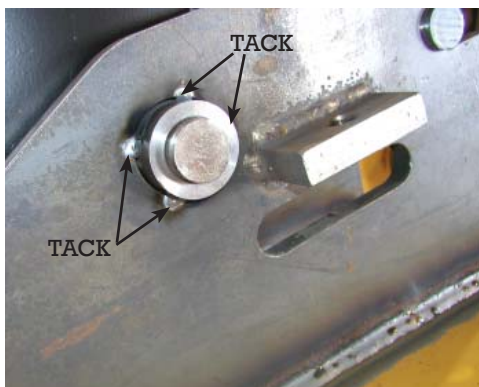

Fig. 10



Fig. 11

**TRIMMING "UNIVERSAL" MOUNTS
TO FIT THE BUCKET**

NOTE

IGNORE THIS SECTION IF YOU RECEIVED A MOUNT KIT MADE FOR YOUR SPECIFIC BUCKET (which happens 99% of the time - this Section is rarely needed)

Grabtec Inc will make every effort to provide a Mount Kit that is designed to fit your bucket and will locate the grapple in the proper position. However, rare cases do occur when a "universal" mount kit is all that can be supplied. The four 3/4" thick hook plates that are included in the mount kit will need to be trimmed to fit the profile of your bucket and to position the grapple properly in respect to the cutting edge of the bucket.

STEP 1 (See Figure 1)

The positioning template is furnished in 3 parts. Tack weld the three parts together as shown.

STEP 2 (See Figure 2)

Position the template over the bucket so that the tip of the template (which represents the tips of the grapple teeth) is in the desired position. Please note that the tip should be approximately 3" above the ground. If the tip is inside the bucket, or within 1" of the cutting edge or cutting edge bolt, it is possible for the grapple teeth to contact them when the grapple is dismounted.

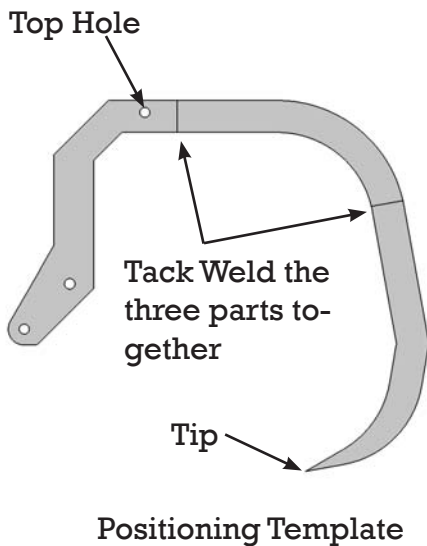

Fig. 1

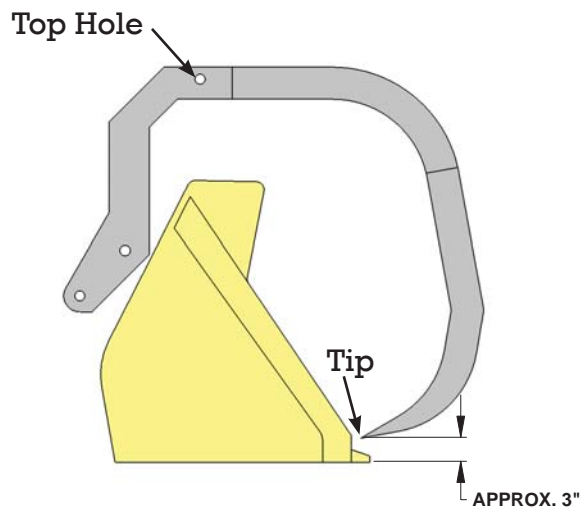

Fig. 2

**TRIMMING "UNIVERSAL" MOUNTS
TO FIT THE BUCKET**

IGNORE THIS SECTION IF YOU RECEIVED A MOUNT KIT MADE FOR YOUR SPECIFIC BUCKET (which happens 99% of the time - this Section is rarely needed)

STEP 3 (See Figure 3)

If you did not purchase the optional template like the one used in Steps 1 and 2, another way to know the relation between the top hook plate hole and the position of the grapple teeth is by taking a few measurements. In Figure 3, notice that the tip of the grapple teeth will be 24 inches below the top hole and 29 inches in front of it. The proper angle of the top edge of the hook plate is 45 degrees as shown. Typically, you want the grapple teeth 2-3 inches above the very front of the cutting edge. From this imaginary point, measure back 29 inches and up 24 inches and you will know approximately where the top hole of the hook plates has to be.

STEP 4 (See Figure 4)

Once you know where the top hole of the hook plate should be located on your bucket, you must transfer the profile (shape) of the bucket onto the universal hook plates so that they can be trimmed to fit. Please note that the shape of the trimmed hook in Figure 4 is for demonstration only and may not look anything like the shape required for your bucket.

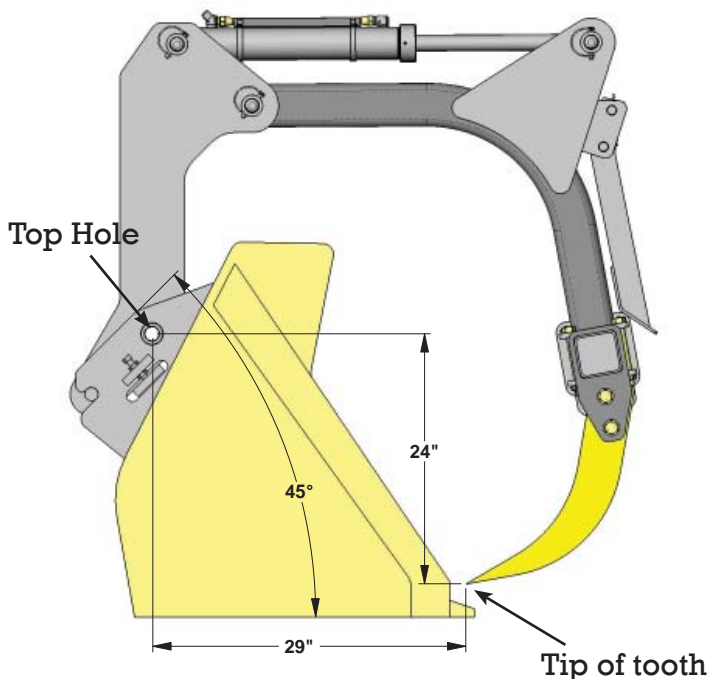

Fig. 3

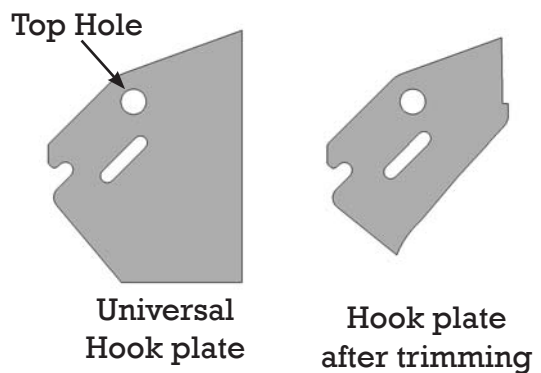

Fig. 4

ASSEMBLY OF GRAPPLE ONTO BUCKET

! WARNING

USE A CRANE OR A HOIST TO LIFT ALL ITEMS THAT WEIGH MORE THAN 50 LBS

NOTE

Reviewing the Parts Listing found later in this Manual will assist in relating the part descriptions in the Instructions with items used for assembly

STEP 1 (See Figure 1)

Position torque tube assembly onto the mount that is welded on the bucket and secure the torque tube with the retaining pin.

CAUTION

The zero-maintenance feature of the pivot pins and pivot housings of the Grabtec grapple is dependant upon proper care when installing the pins. Please read the "Maintenance" section of this manual before installing any of the pivot pins.

STEP 2 (See Figure 2)

Using a 1-1/2" diameter chrome pivot pin, connect the pivot assembly to the torque tube. In preparation for the installation of the cylinder, lift and support the pivot assembly as shown. Secure the pivot pin using a 3/8 x 3 bolt and nylock nut.



Fig. 1



Fig. 2

Fig. 3

STEP 3 (See Figure 3)

Install a cylinder between the torque tube and pivot assembly as shown. The two cylinders that came with the grapple are identical, there is not a right and a left cylinder. Secure the pins using 3/8 x 3 bolts and nylock nuts (not the snap lock pins that are in the picture).

STEP 4 (See Figure 4)

Bolt the outer tooth bars to the center tube using (8) 3/4 x 2 bolts and top-lock nuts.

STEP 5 (See Figure 5)

Lift the tooth tube up to the pivot tubes and drop the long 3/4" bolts into the upper clamp plates.

STEP 6 (See Figure 6)

Install the two lower clamp plates, center the tooth tube between the pivot tubes and tighten the nuts .

STEP 7 (See Figure 7)

Install the teeth using the 3/4 x 2-3/4 bolts and top-lock nuts. Be sure to place hardened washers under the bolt heads and under the nuts.



Fig. 3



Fig. 4



Fig. 5



Fig. 6



Fig. 7

STEP 8 (See Figure 8)

Install the stand legs using the 3/4" diameter clevis pins and hairpin cotters.

STEP 9 (See Figure 9)

Install the support plates, set screws and jam nuts. See page 17 for details on installing these items and how they are used for adjustments.

STEP 10 (See Figure 10)

Install supply hoses and tees that go inbetween the cylinders. The lengths of these hoses depend on the grapple model. Use the hose connection sketch on page 26 as a guide. It is important that each tee is supplying the proper ports on the cylinders so that the cylinders work together. A short piece of hose wrap (26" long) should go between the cylinder ports and the hose clamp on the back of the torque tube. Longer lengths of hose wrap can be installed between the hose clamps and the tees. The position of the tees (bucket center, left, or right) will depend on where the loader's auxiliary hoses are located on the loader boom.

STEP 11 (See Figure 11)

Your mount kit included (2) J-hooks. Weld one of these hooks on each side of the bucket in such a position that they keep the supply hoses from getting pinched when the bucket is rolled all the way back.



Fig. 8



Fig. 9



Fig. 10

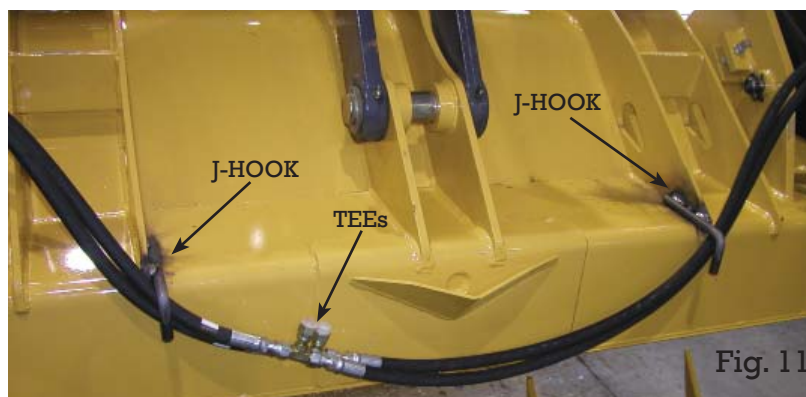

Fig. 11

QUICK-DISCONNECTING THE GRAPPLE FROM THE BUCKET

STEP 1 (See Figure 1)

Drive bucket over level, hard ground and tilt it forward as shown. Move the parking stands to their park position, making sure that the pad of the stand is facing the ground.



◇ **DO NOT STAND IN FRONT OF THE BUCKET AND GRAPPLE WHEN PERFORMING STEP 2. STAND TO THE SIDE.**

STEP 2 (See Figure 2)

Note how the bucket is tilted downward enough so that the retaining pin is below hook pin. This will ensure that the weight of the grapple is restrained by the hook pin. Pull out the retaining pins that secure the grapple to the mounts. If the pins are difficult to remove, it may be necessary to adjust the support plates. See the section titled "Adjustment of the Support Plates" found later in this manual.

Fig. 1



Fig. 2



QUICK-DISCONNECTING THE GRAPPLE FROM THE BUCKET

STEP 3 (See Figure 3)

Disconnect the grapple hydraulic hoses from the wheel loader's auxiliary supply.

STEP 4 (See Figure 4)

Lower the bucket and grapple to the ground so that the stand legs and the outer curved edge of the teeth touch the ground at about the same time.

STEP 5 (See Figure 5)

Rotate the bucket to un-hook the mounts from the hook pins of the grapple and back away.



Fig. 3



Fig. 4



Fig. 5

QUICK-CONNECTING THE GRAPPLE TO THE BUCKET

STEP 1 (See Figure 1)

Approach the grapple with the floor of the bucket nearly straight up and down.

STEP 2 (See Figure 2)

Hook the mounts into the hook pins of the grapple and begin rotating the bucket until the grapple is just slightly lifted off the ground and the weight of the grapple is still supported by the hook pins.

STEP 3 (See Figure 3)

Insert the retaining pins that secure the grapple to the mounts. If the pins are difficult to install, it may be necessary to adjust the support plates. See the section titled "Adjustment of the Support Plates" found later in this manual.



Fig. 1



Fig. 2



Fig. 3

QUICK-CONNECTING THE GRAPPLE TO THE BUCKET

STEP 4 (See Figure 4)

Connect the grapple hydraulic hoses to the backhoe's auxiliary supply.

STEP 5 (See Figure 5)

Place the stand legs in their store position.



Fig. 4

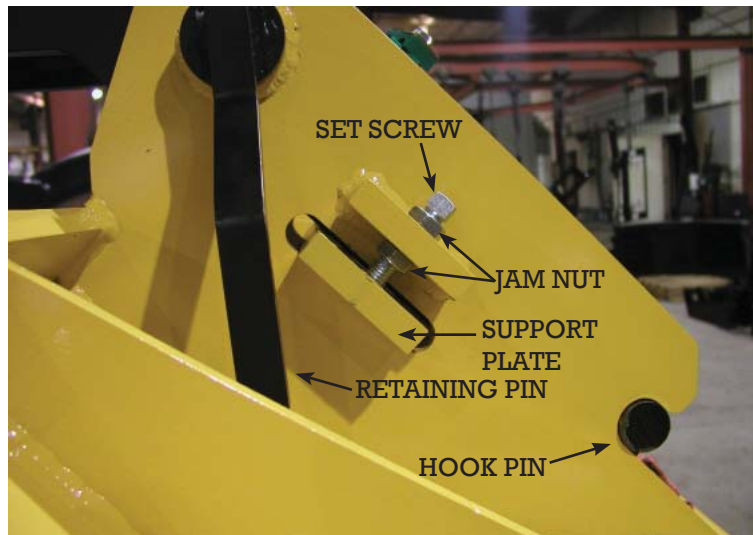

Fig. 5

ADJUSTMENT OF THE SUPPORT PLATES

NOTE

The photo below shows the grapple when the bucket is flat on the ground. For best results, adjustment of the support plates should take place when the weight of the grapple is being supported by the hook pins, as shown in Fig 2 of "Quick Disconnecting the Grapple from the Bucket" on Page 13.



The Grabtec grapples have a unique feature in that they can be quickly disconnected from the bucket by removing two pins. There are two critical requirements that allow the pins to be removed easily (by hand). The first is that the mounts were installed correctly and that the collars that the pins slide through are properly aligned with the grapple. The second is that the support plates are adjusted correctly.

FUNCTION

When turned in the proper directions, the jam nuts and set screws can raise or lower the support plate. The support plate is "supporting" the grapple. When the support plate is moved, the grapple rotates about the hook pin and the upper holes in the mount that the retaining pin slides through can be better aligned with the long sleeve in the grapple. As the alignment improves, the retaining pin is more easily installed (or pulled out).

TO ADJUST THE SUPPORT PLATES UPWARD

Loosen the lower jam nut. Turn the top jam nut clockwise while keeping the set screw from turning. When proper adjustment is achieved, tighten both jam nuts.

TO ADJUST THE SUPPORT PLATES DOWNWARD

Loosen the top jam nut. Turn the lower jam nut counter-clockwise while keeping the set screw from turning. When proper adjustment is achieved, tighten both jam nuts.

MAINTENANCE

NOTE

The pivots on each end of the cylinders and the main pivots for the grapple frame are equipped with zero-maintenance bushings. There are no grease zerks on the grapple. Each end of the bushing housings are equipped with wiper-style dust seals to keep out debris. This pin system has proven to provide years and years of service in severe duty environments, provided the following precautions are met:

- ◇ **IF YOU REMOVE A PIVOT PIN, MAKE SURE IT IS CLEAN AND DRY BEFORE YOU REINSTALL IT.**
- ◇ **IF YOU REMOVE A PIVOT PIN, DO NOT PERFORM ANY GRINDING OR WELDING THAT WOULD ALLOW PARTICLES TO ENTER THE BEARING HOUSING.**
- ◇ **DO NOT ATTEMPT TO LUBRICATE THE PINS WITH ANYTHING.**
- ◇ **IF A DUST SEAL (WIPER SEAL) THAT PROTECTS THE BEARING HOUSING IS DAMAGED, REPLACE IT.**
- ◇ **DO NOT REPLACE A PIVOT PIN WITH ANYTHING OTHER THAN A GRABTEC PIVOT PIN MADE FOR YOUR GRAPPLE MODEL. THE EXTREMELY DURABLE AND HARD CHROME FINISH OF THE GRABTEC PINS IS IMPORTANT FOR THE LIFE OF THE BUSHINGS AND FOR THE RESISTANCE TO CORROSION IN THE PIN HOUSING.**

MAINTENANCE PROCEDURES

PROCEDURE	INTERVAL	NOTES
Check for hydraulic fluid leaks	Daily	Look at hose connections and hose fittings
Check bolt tightness	Daily	Torque 3/4-10 nuts to 310 ft-lbs
Check for build-up around pivot areas	Daily	Remove ice, ground hay or any other debris from all pivot areas.

PARTS INDEX

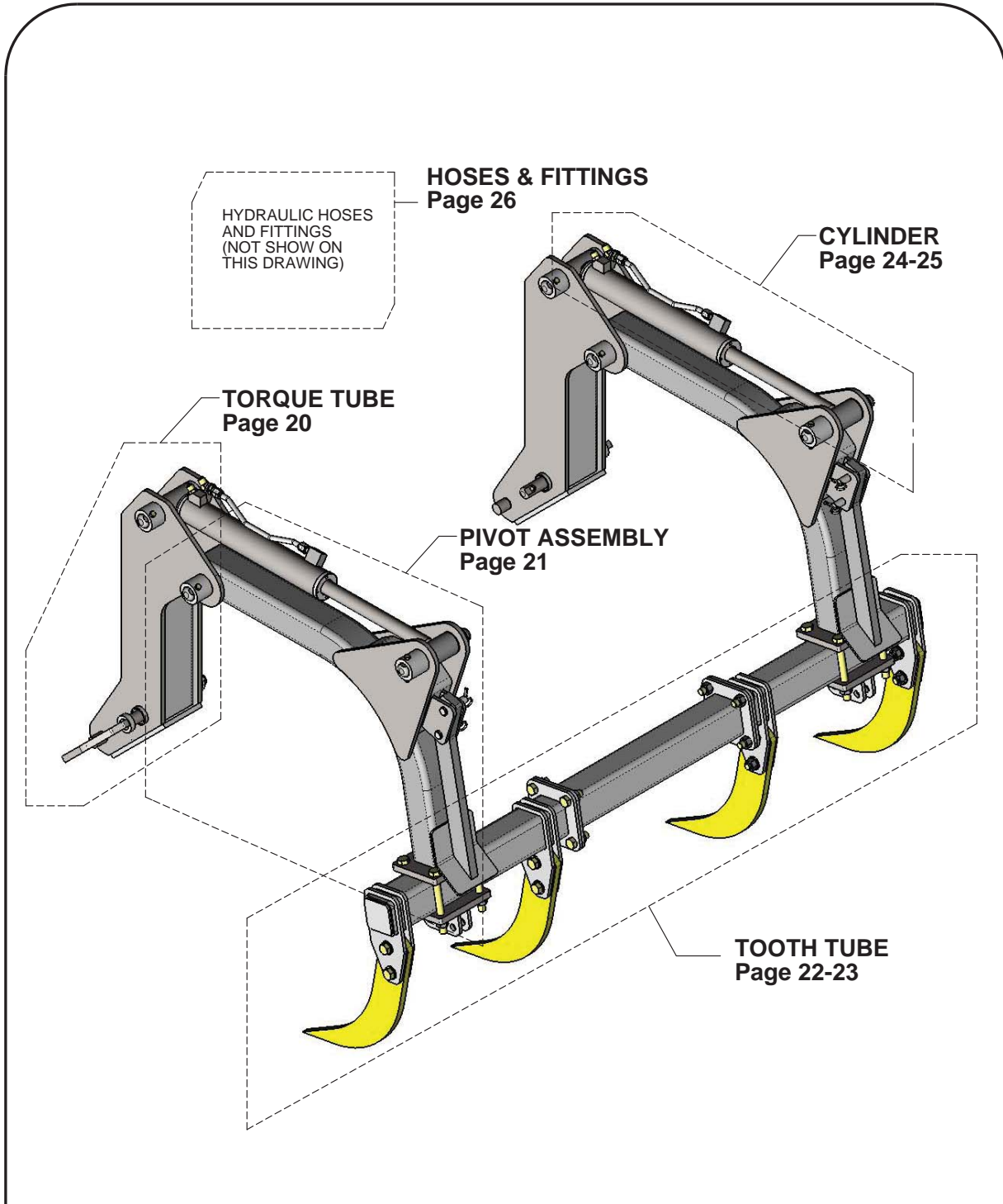

PART INDEX

PRODUCT MODEL: **GB**

DRAWING ID#: GB-S4
DRAWING REVISION: -
DRAWING DATE: 3/8/2012

TORQUE TUBE

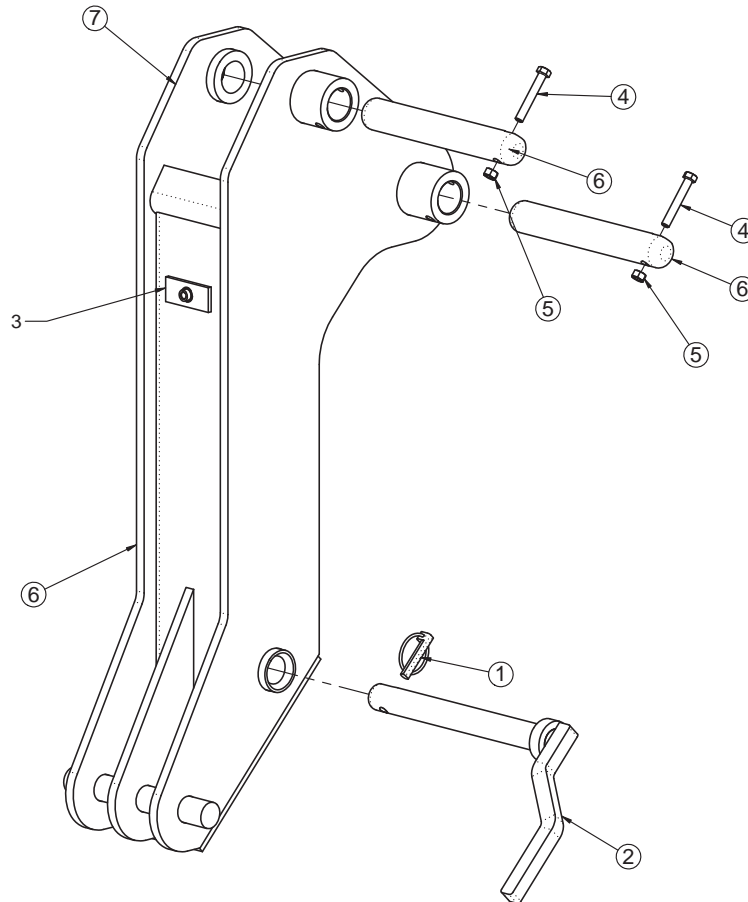

ITEM NO.	PART NUMBER	DESCRIPTION	Approx. Weight (LBS)	QTY. SHOWN
1	98441	LYNCH PIN, 7/16 X 1-3/4	0.1	1
2	GC010	LOCK PIN ASSEMBLY	6.0	1
3	90800	TWIN HOSE CLAMP	0.3	1
4	98201	BOLT, 3/8 X 2-1/2, GR8, ZP	1.0	2
5	98006	NUT, 3/8-16 NYLOCK, ZP	0.2	2
6	60230	PIN, 1.50 X 9.75	4.7	2
7	GB102	TORQUE TUBE, GB, REV. B	137.0	1

TORQUE TUBE

PRODUCT MODEL: **GB**

DRAWING ID#: GB-S4
 DRAWING REVISION: -
 DRAWING DATE: 3/8/2012

PIVOT ASSEMBLY

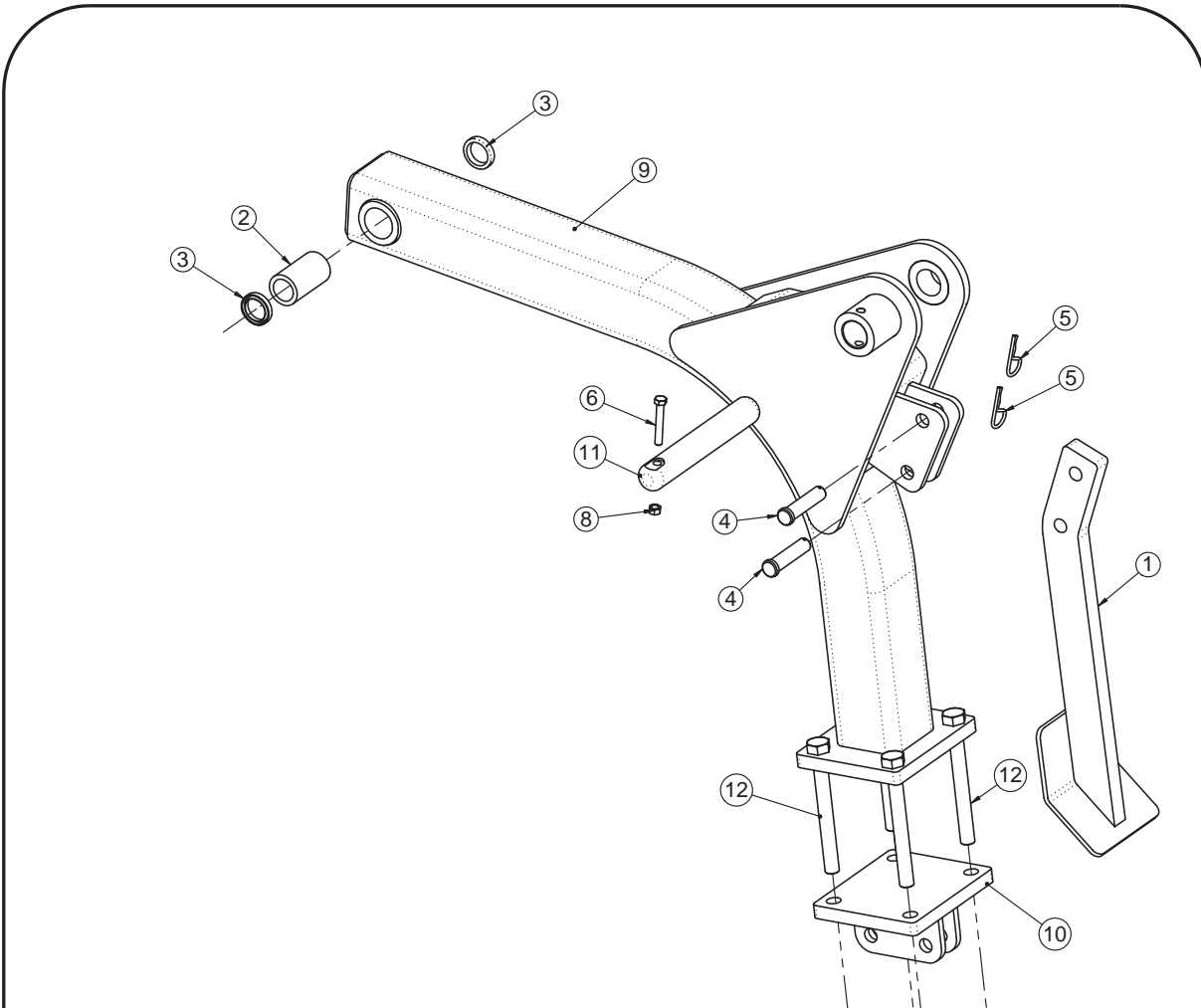

ITEM NO.	PART NUMBER	DESCRIPTION	Approx. Weight (LBS)	QTY SHOWN
1	GA005	STAND LEG ASSEMBLY	16.5	1
2	98550	COMPOSITE BEARING, 1.25 BORE, 3.125 LONG	0.2	1
3	94221	PIN SEAL, 1.25 ID x 1.75 OD x 5/16 Thick	0.0	2
4	98401	PIN, ZINC PLATED, 3/4 X 3	0.3	2
5	98431	HAIRPIN COTTER, ZINC, 2-11/16 OAL	0.1	2
6	98201	BOLT, 3/8 X 2-1/2, GR8, ZP	1.0	1
7	98015	NUT, 3/4-10 UNC TOP LOCK, PLATED	0.2	4
8	98006	NUT, 3/8-16 NYLOCK, ZP	0.2	1
9	GC101	PIVOT ASSEMBLY	130.6	1
10	GC104	COMBO CLAMP PLATE	13.2	1
11	60230	PIN, 1.50 X 9.75	4.7	1
12	98210	BOLT, 3/4-10 UNC, GR8 ZN, 7" LONG	1.0	4

PIVOT TUBE

PRODUCT MODEL: GC,GB

DRAWING ID#: GB-S4
 DRAWING REVISION: -
 DRAWING DATE: 3/8/2012

TOOTH TUBES (5-TOOTH)

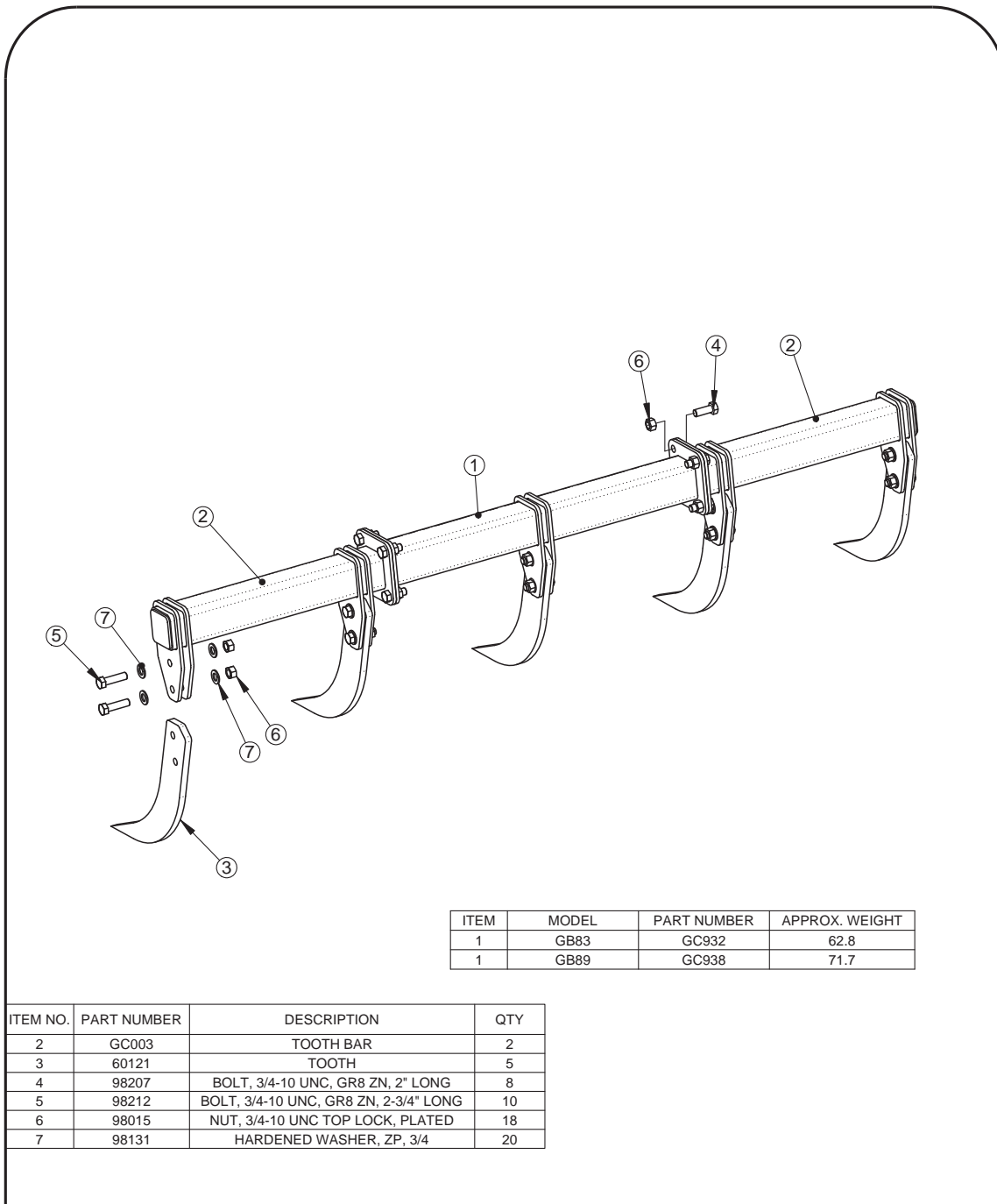

ITEM	MODEL	PART NUMBER	APPROX. WEIGHT
1	GB83	GC932	62.8
1	GB89	GC938	71.7

ITEM NO.	PART NUMBER	DESCRIPTION	QTY
2	GC003	TOOTH BAR	2
3	60121	TOOTH	5
4	98207	BOLT, 3/4-10 UNC, GR8 ZN, 2" LONG	8
5	98212	BOLT, 3/4-10 UNC, GR8 ZN, 2-3/4" LONG	10
6	98015	NUT, 3/4-10 UNC TOP LOCK, PLATED	18
7	98131	HARDENED WASHER, ZP, 3/4	20

TOOTH TUBE (5 TOOTH MODELS)

PRODUCT MODEL: GC,GB	DRAWING ID#: GB2-S2
	DRAWING REVISION: -
	DRAWING DATE: 3/8/2012

TOOTH TUBES (4-TOOTH)

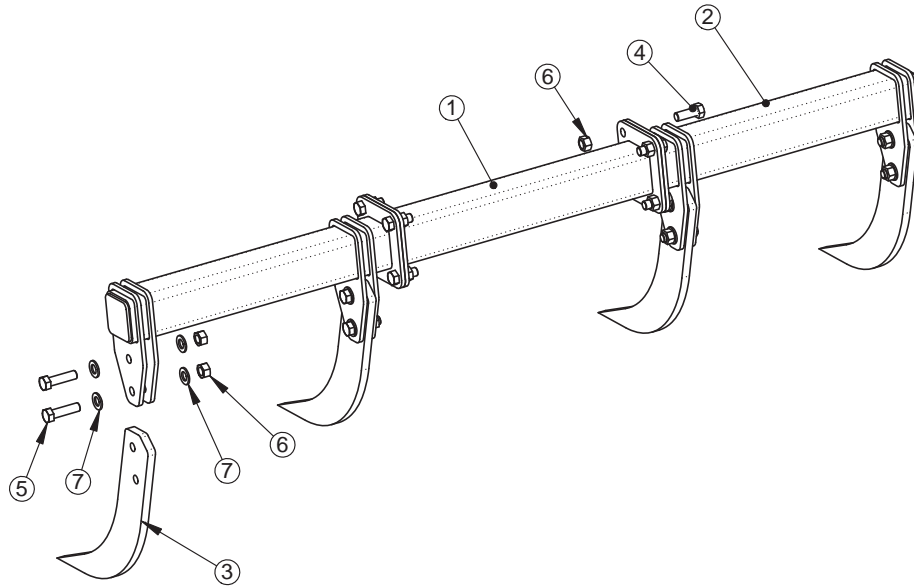

ITEM	MODEL	PART NUMBER	APPROX. WEIGHT
1	GB71	GC920	38.5
1	GB77	GC926	47.4

ITEM NO.	PART NUMBER	DESCRIPTION	QTY
2	GC003	TOOTH BAR	2
3	60121	TOOTH	4
4	98207	BOLT, 3/4-10 UNC, GR8 ZN, 2" LONG	8
5	98212	BOLT, 3/4-10 UNC, GR8 ZN, 2-3/4" LONG	8
6	98015	NUT, 3/4-10 UNC TOP LOCK, PLATED	16
7	98131	HARDENED WASHER, ZP, 3/4	16

TOOTH TUBE (4 TOOTH MODELS)

PRODUCT MODEL: **GC,GB**

DRAWING ID#: GB2-S2
 DRAWING REVISION: -
 DRAWING DATE: 3/8/2012

CYLINDER, GENERAL

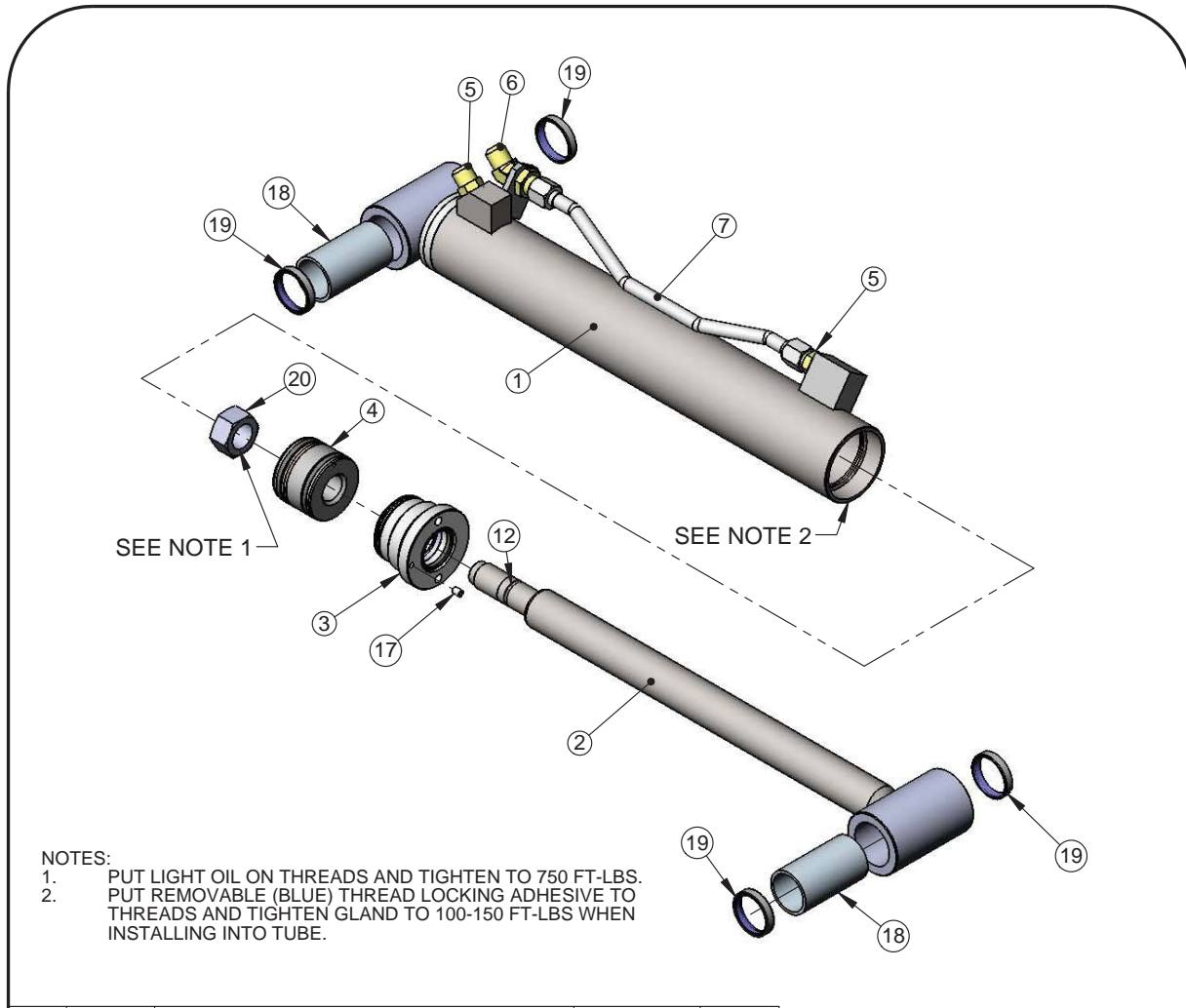

- NOTES:
1. PUT LIGHT OIL ON THREADS AND TIGHTEN TO 750 FT-LBS.
 2. PUT REMOVABLE (BLUE) THREAD LOCKING ADHESIVE TO THREADS AND TIGHTEN GLAND TO 100-150 FT-LBS WHEN INSTALLING INTO TUBE.

ITEM NO.	PART NUMBER	DESCRIPTION	Approx. Weight (LBS)	QTY. SHOWN
1	GC123	TUBE ASSEMBLY (GC), AGILE	17.3	1
2	GC022	ROD ASSEMBLY	12.2	1
3	90159	GLAND, GC	1.83	1
4	90113	PISTON, GC, OFFSET SEAL, NO THREADS	1.79	1
5	90510C	ADAPTER, -8 MJIC -6MORB	0.12	2
6	90513A	BULKHEAD ADAPTER W/NUT, 45 DEG. MJIC -08	0.35	1
7	GC024	FLUID LINE ASSEMBLY, GC	0.49	1
12	94121	O-RING, -117, 13/16 ID X 1 OD, N70	0.00	1
17	98712	SOCKET SET SCREW, CUP 1/4-20 X 3/8 LONG	0.0	1
18	98650	COMPOSITE BEARING, 1.50 BORE, 3.125 LONG	0.2	2
19	94223	PIN SEAL, 1.50 ID x 1.75 OD x 3/8 Thick	0.0	4
20	98016	NUT, 1-14 UNF GR8 TL, PLAIN	0.3	1

THE PART NUMBER FOR AN ASSEMBLED CYLINDER IS **GC121**. THE PIN SEALS (ITEM 19) AND BEARINGS (ITEM 18) MUST BE ORDERED SEPARATELY.

SEAL KIT FOR THIS CYLINDER (SEE NEXT PAGE FOR DETAILS)
PART # 94407

GC121 CYLINDER PARTS, GENERAL

PRODUCT MODEL:	DRAWING ID#:	GC121S
	DRAWING REVISION:	RevB
	DRAWING DATE:	4/12/2011

CYLINDER, DETAIL

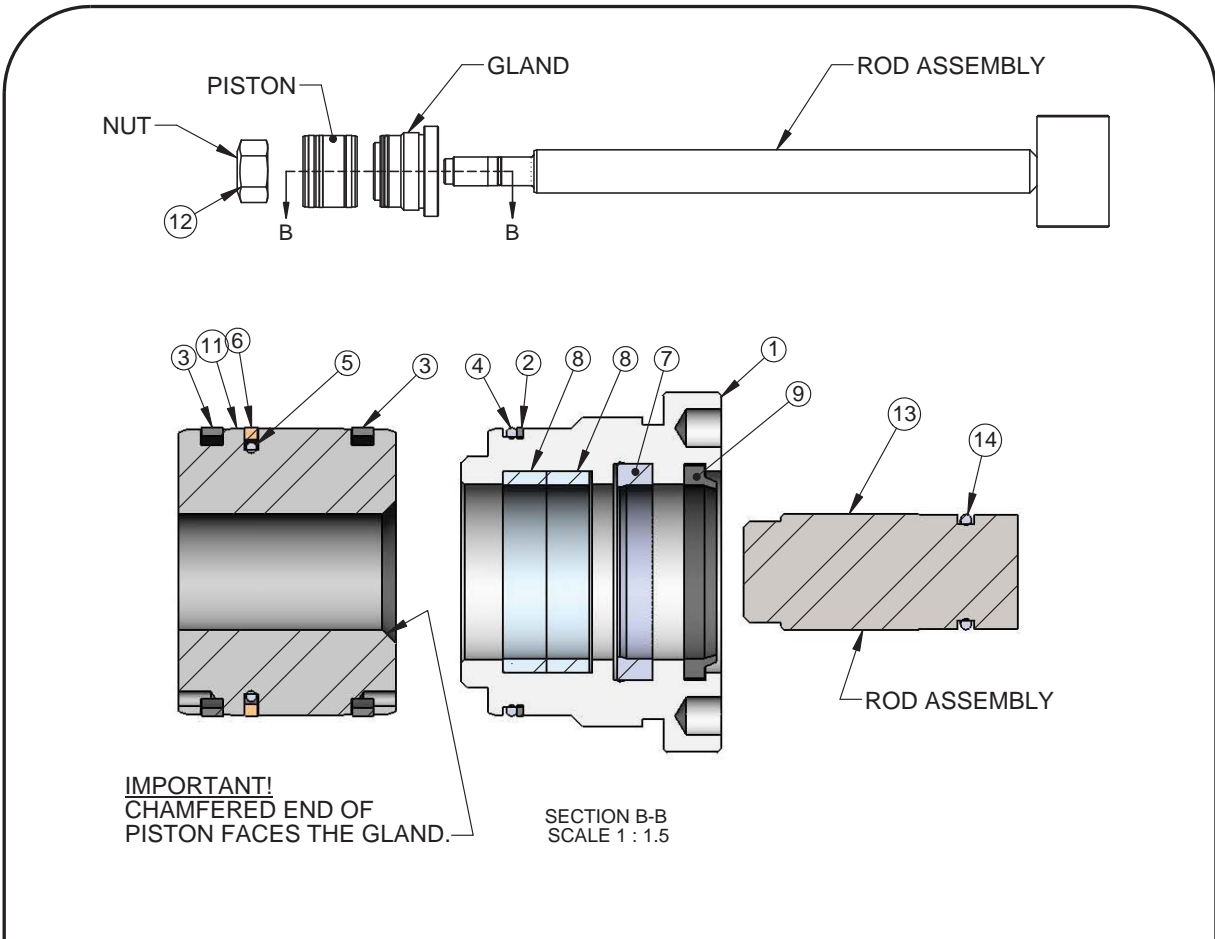

ITEM NO.	PART NUMBER	DESCRIPTION	Approx. Weight (LBS)	QTY	Included with Seal Kit 94407?
1	90159	GLAND, GC	1.83	1	N
2	94107	BACK UP RING, -141, 2-1/2" OD	0.00	1	Y
3	94192	CAST IRON RING, 2-1/2" OD X 3/16" WIDE	0.02	2	N
4	94123	O-RING, -141, 2-5/16 ID X 2-1/2 OD, N70	0.00	1	Y
5	94122	O-RING, -137, 2-1/16 ID X 2-1/4 OD, N70	0.00	1	Y
6	94154	POLYHONE (HYTREL), 2.50 OD	0.00	1	Y
7	94170	SEAL, U-CUP, 1.5 X 1.875 X 5/16	0.01	1	Y
8	94185	WEAR RING, ROD, 1-1/2 X 3/8" WIDE	0.03	2	Y
9	94212	WIPER, 1.50 ROD, TYPE "D"	0.01	1	Y
11	90113	PISTON, GC, OFFSET SEAL, NO THREADS	1.79	1	N
12	98018	TOP LOCK NUT, 1-1/4 -12 GR C	0.3	1	N
13	GC022	ROD ASSEMBLY	12.2	1	N
14	94121	O-RING, -117, 13/16 ID X 1 OD, N70	0.00	1	Y

SEAL KIT FOR THIS CYLINDER PART # 94407

GC121 CYLINDER PARTS, DETAIL	
PRODUCT MODEL:	DRAWING ID#: GC121S DRAWING REVISION: RevB DRAWING DATE: 4/12/2011

HOSE CONNECTIONS

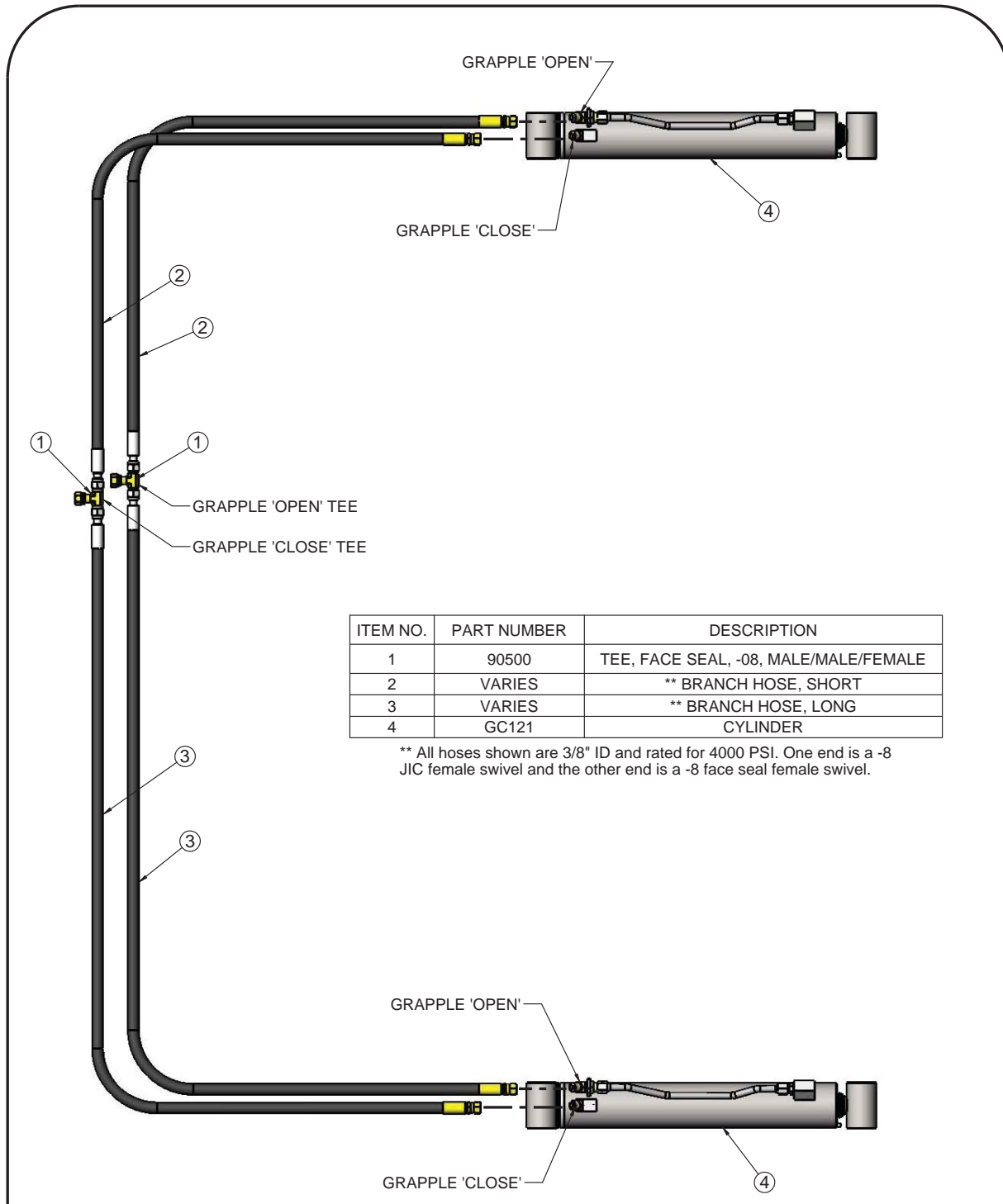

ITEM NO.	PART NUMBER	DESCRIPTION
1	90500	TEE, FACE SEAL, -08, MALE/MALE/FEMALE
2	VARIES	** BRANCH HOSE, SHORT
3	VARIES	** BRANCH HOSE, LONG
4	GC121	CYLINDER

** All hoses shown are 3/8" ID and rated for 4000 PSI. One end is a -8 JIC female swivel and the other end is a -8 face seal female swivel.

HOSE CONNECTIONS

PRODUCT MODEL: GC

DRAWING ID#: GC-S3
 DRAWING REVISION: -
 DRAWING DATE: 2/12/2009

MOUNT KIT PARTS

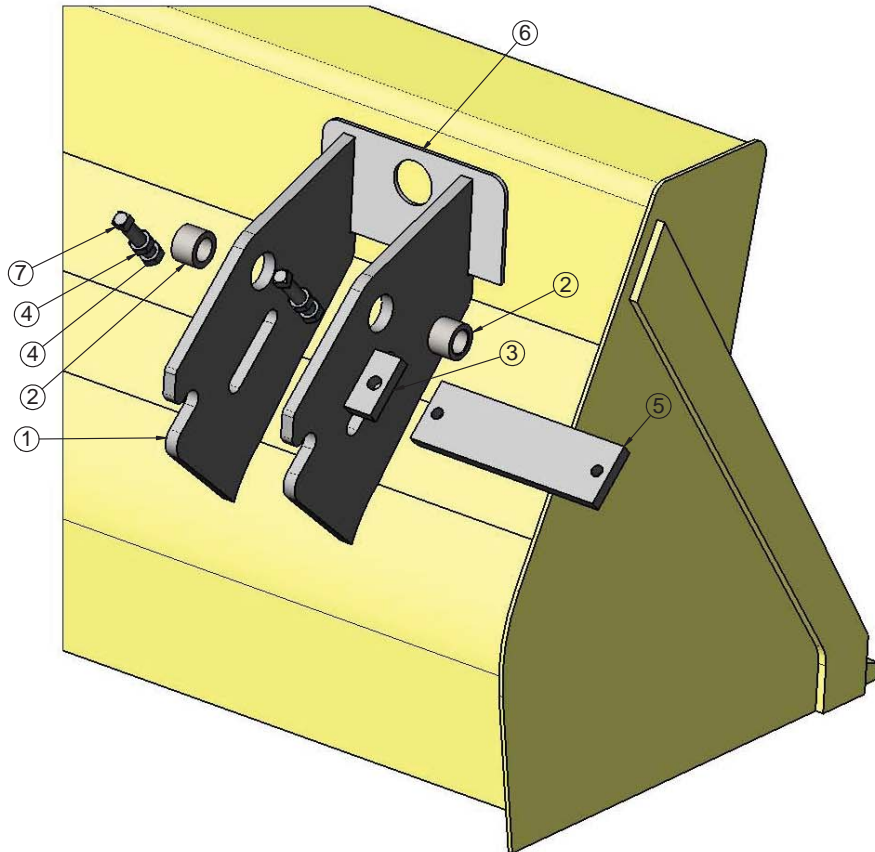

ITEM NO.	PART NUMBER	DESCRIPTION	Approx. Weight (LBS)	QTY SHOWN
1	42000	HOOK PLATE, VARIES WITH APPLICATION	29.63	2
2	60108	BUCKET LUG COLLAR	0.691	2
3	40098	BLOCK WITH HOLE	1.12	2
4	98012	JAM NUT, 3/4 NC, ZN	0.2	4
5	40096	SUPPORT PLATE, GC	8.80	1
6	40099	DOUBLER PLATE	4.73	1
7	98715	SET SCREW, 3/4 X 4, SQ. HEAD, CUP	0.6	2

MOUNT KIT

PRODUCT MODEL: GB

DRAWING ID#: GB-S4
 DRAWING REVISION: -
 DRAWING DATE: 3/8/2012

IDENTIFYING YOUR GRAPPLE MODEL & SERIAL



The Serial plate is typically found on the rear of the right side torque tube.

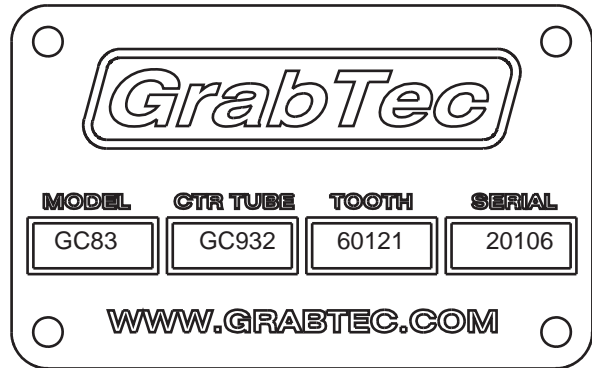

The serial plate shows the Model and Serial number of your grapple. The plate also shows the part numbers for a replacement Center tube or replacement tooth.

PRODUCT CHANGES AND SERIAL BREAK INFO

Revision ID	Models Affected	Starting Serial #	Ending Serial #	Revision Details	Parts Affected	See Pages
-	All GB models	18000	20314	None - original design	N/A	N/A
B5 Feb 2008	All GB models	20315	-	Updated Cylinder design	Cylinder GC011 replaced with Cylinder GC021. Cylinders are interchangeable, but all internal parts are different.	-
B9 Nov 2008	All GB models	20523	-	Set screws for support plates increased to 3/4 diameter	Support plates, set screws, jams nuts	27
B10 Feb 2009	All GB models	20600	-	Switched cylinder supplier. Radius added to the cylinder rod stem. The chamfered edge on the piston ID changed to a radiused edge.	Cylinder GC021 is now GC121. Complete cylinders are interchangeable. Seal kits remain the same.	24,25
B25 Mar 2011	All GB models	20868	-	Increased pin diameter from 1-1/4" to 1-1/2". Clamp plate thickness increased from 1/2" to 3/4".	All pin collars on Torque Tube and Pivot assemblies are larger. Pivot bearings and seals are larger. Clamp bolts are 7" long instead of 6".	20,21

SPECIFICATIONS

**MODEL
"GB"**

APPLICABLE
BACKHOE
BUCKET SIZE
1.0 - 1.6 YD³

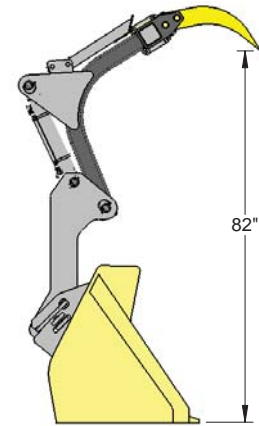
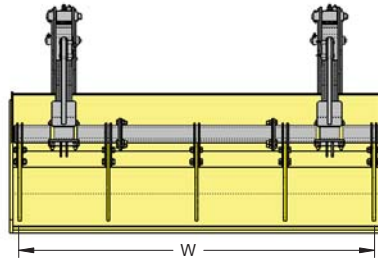
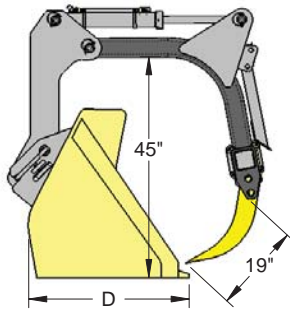

General Specifications for Model 'GB' Grapple

Max. Opening, Ground to teeth	82"
Number of Teeth available	4 or 5
Tooth thickness and material	3/4" Gr. 80 (80,000 psi yield) steel
Teeth replaceable?	yes, each tooth secured by (2) 3/4" Gr. 8 bolts
Max. Clamping force at tips of teeth with 3750 psi	6,800 lb.
Grapple opening time with 15GPM	2.5 sec. (flow to cylinders is NOT restricted. Cylinders feature internal hydraulic cushioning when closing)
Depth of typical bucket for proper fitment (see dimension "D" above)	27"-35"
Bore and stroke of cylinders	2.50 inch bore and 14.9" stroke
Cylinder Pressure rating	4,000 psi
Diameter of main grapple pivot pins	1.5"
Diameter of cylinder pivot pins	1.5"
Pivot pin bushing and seal info	Self-Lubricating, zero-maintenance, replaceable bushings with dust seals on each on of bushing.
Custom fitment	The Quick-attach models are custom designed for the bucket already on the backhoe.
General type of steel used for grapple construction	T-1 (100,000 psi yield) and Grade 80 (80,000 psi yield)

'GB' QUICK-ATTACH MODELS			
MODEL	GRAPPLE WIDTH [W]	NO. of TEETH	INSTALLED WEIGHT
GB77	77"	4	1055 lbs
GB83	83"	5	1080 lbs
GB89	89"	5	1090 lbs

WARRANTY



1242 Arizona Ave
Larchwood, IA 51241
712-477-2675
888-857-8952
712-477-2500 FAX

Grabtec warrants its grapples against faulty design, material, and workmanship for a period of one year from date of delivery or 2,000 hours, whichever comes first. The composite bushings located at cylinder and grapple pivot points are warranted against breakage or loss of their self-lubricating properties for three years or 5,000 hours, whichever comes first. Refer to the Maintenance section of the Owner's Manual for proper care and precautions concerning the pivot bushings. The warranted coverage on the grapples or pivot bushings is for the parts only, not for labor to disassemble or reassemble the grapple or to remove or reinstall the bushings or for shipping costs.

If Grabtec installs the mounts on the bucket, Grabtec warrants the mounts against faulty design, material, or workmanship for a period of one year from date of delivery or 2,000 hours, whichever comes first. If Grabtec does not install the mounts, Grabtec warrants the mounts against faulty material for a period of one year from date of delivery or 2,000 hours, whichever comes first.

If Grabtec provides mounts that were designed with information supplied by the customer, Grabtec will not warranty the mounts against improper fitment. Grabtec will make every effort to design mounts that fit with minimal reshaping, but accepts no responsibility for the customer's ability to take accurate measurements of the bucket. If Grabtec provides mounts based on the fact that the customer's bucket is one that Grabtec has previously designed mounts for, Grabtec accepts no responsibility on manufacturing tolerances or design changes to the bucket made by the bucket manufacturer that result in mounts that do not fit without a significant amount of reshaping.

OEM components not manufactured by Grabtec are warranted by Grabtec against failure from improper installation for one year from date of delivery date. Examples of OEM components would be cylinders and cylinder components, hose clamps, hoses, and assembly hardware such as bolts and nuts.

Dealer labor rate charges on approved repairs shall not exceed 70% of dealer regular hourly rate. Overtime charges need prior written approval. Claims received 30 days past the repair date will not be considered for warranty.

Warranty is void if grapples are modified in any manner without PRIOR expressed written permission from Grabtec.

RETURN POLICY



1242 Arizona Ave
Larchwood, IA 51241
712-477-2675
888-857-8952
712-477-2500 FAX

RETURNED GOODS POLICY – PARTS

Items **SHIPPED** in error

Grabtec will accept returned items, with prior approval of Grabtec (see RGA paragraph below), within 30 days after shipment without a restocking charge, freight collect.

Items **ORDERED** in error

When parts are incorrectly ordered and returned to Grabtec, the customer is responsible for freight costs and a 15% restocking fee.

When parts are purchased without reference to a model or serial number and returned to Grabtec, the customer is responsible for freight costs and a 15% restocking fee.

RGA- Returned Goods Authorization

All return items must have prior approval of Grabtec and be assigned an RGA (Returned Goods Authorization) number by either the Grabtec sales or parts department and must be returned within 30 days of request.